

UPPER LEVEL SHORING PLAN

SCALE: 1/4" = 1'-0"
 PLAN NOTES:
 1. SEE S0.0 FOR SYMBOLS LEGEND, ABBREVIATIONS, TYPICAL DETAILS, AND GENERAL NOTES.
 2. SEE S1.1 FOR MORE INFORMATION.
 3. FRAMING MEMBERS SHOWN REPRESENT THE NEWLY-CONSTRUCTED CONDITION WITH NEW AND EXISTING FRAMING MEMBERS IN PLACE.

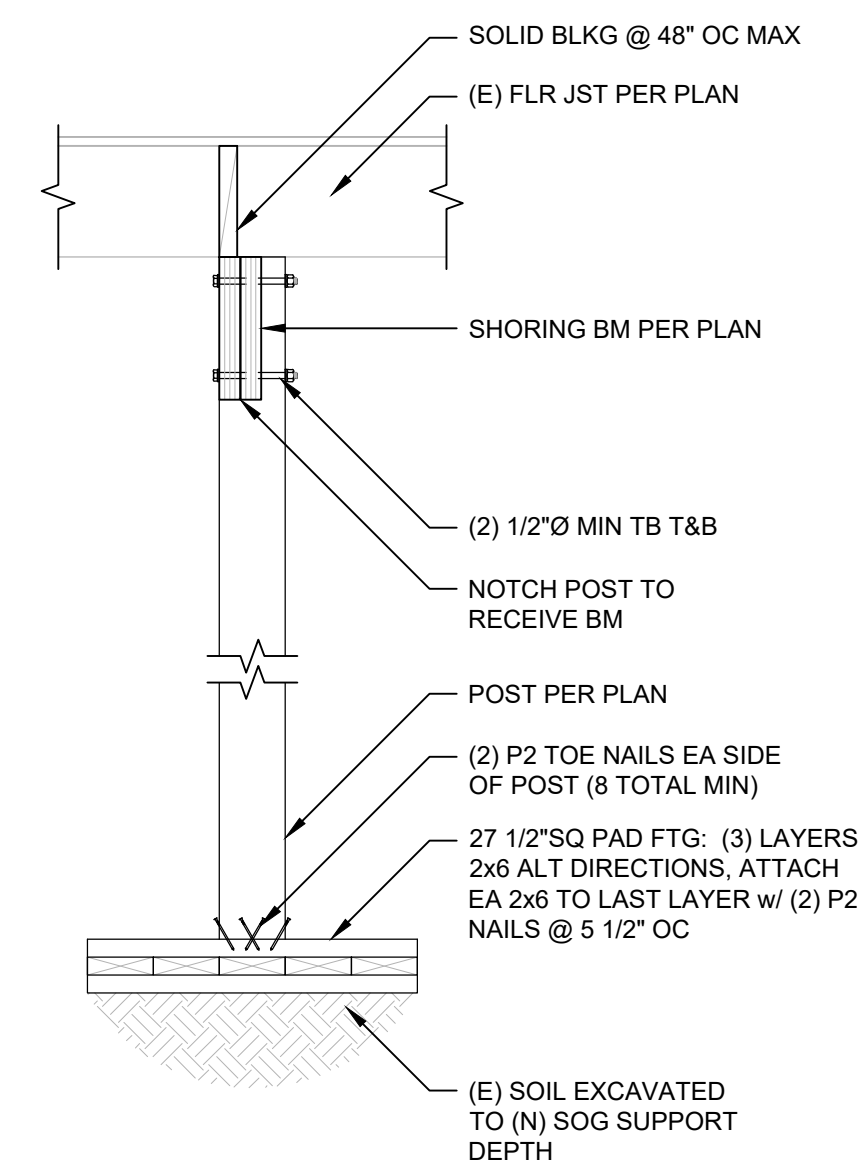

1 TYP SHORE POST & PAD
 SCALE: 3/4" = 1'-0"
 RE: SH-1